

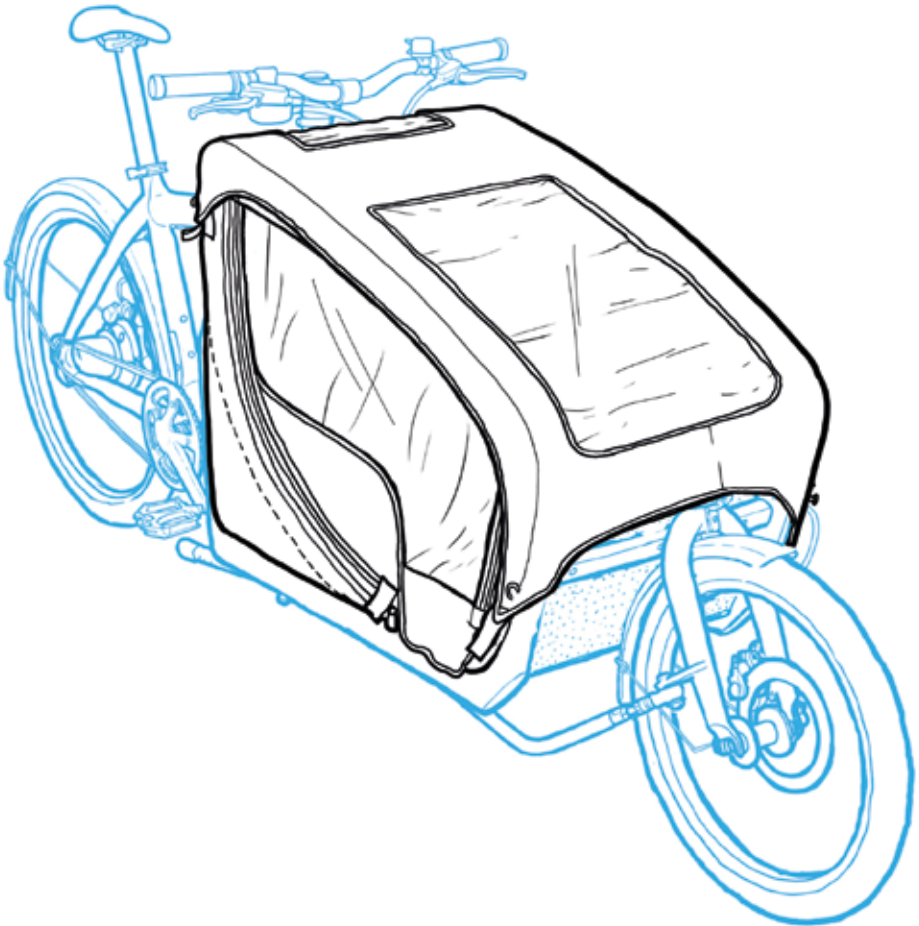

# Canopy Assembly Manual

by Larry vs Harry



# Before you start

Things you need, to attach your brandnew Canopy

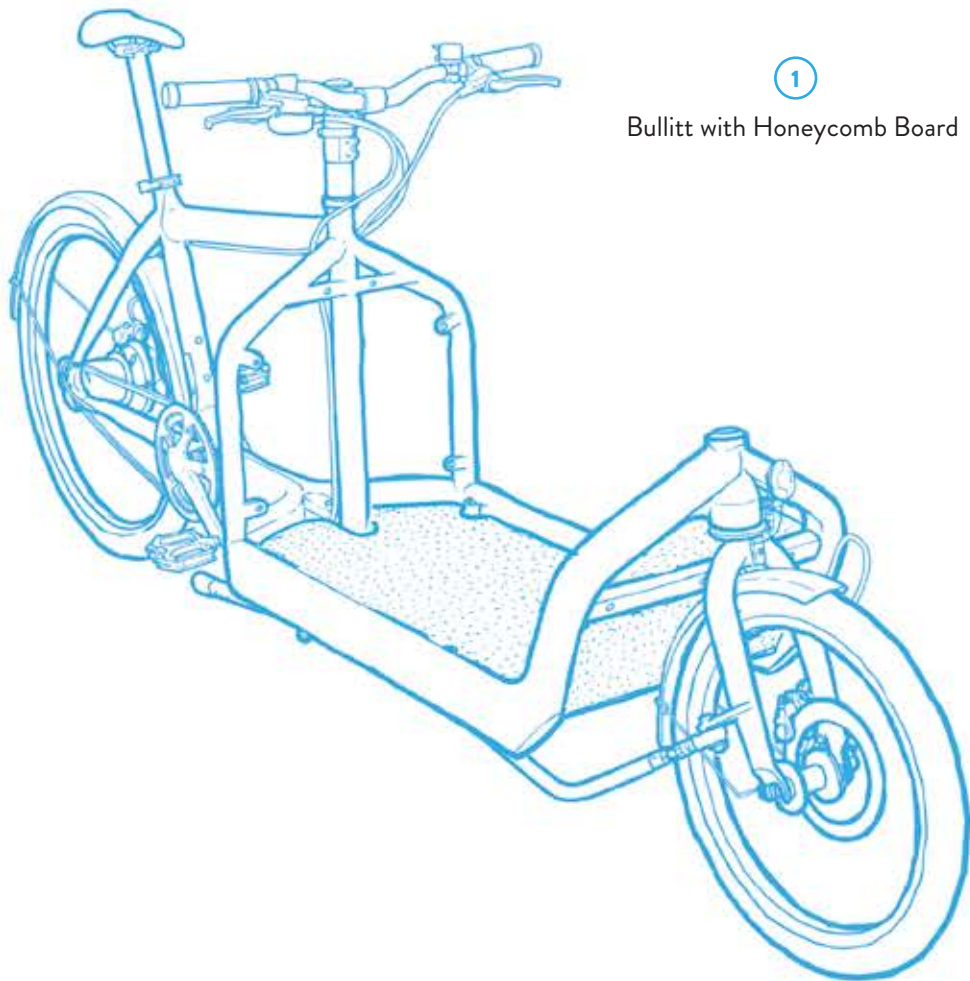

1

Bullitt with Honeycomb Board

2

13 MM  
Wrench/Spanner



3

5 MM  
Hex/Allen key



4

Grease  
(metal on metal)



Larry the King says:  
You think you are pro like me?!  
Real pros read the  
f\*\*\*ing manual!

Icons that will appear throughout the guide:



Ouch! Be careful, you could hurt your fingers.



Grease. Remember to grease or else your mechanic will hate you later on. ("Muc-off" has a Bio Grease that cares about the environment)



Important message from *Larry the King*.

# Components

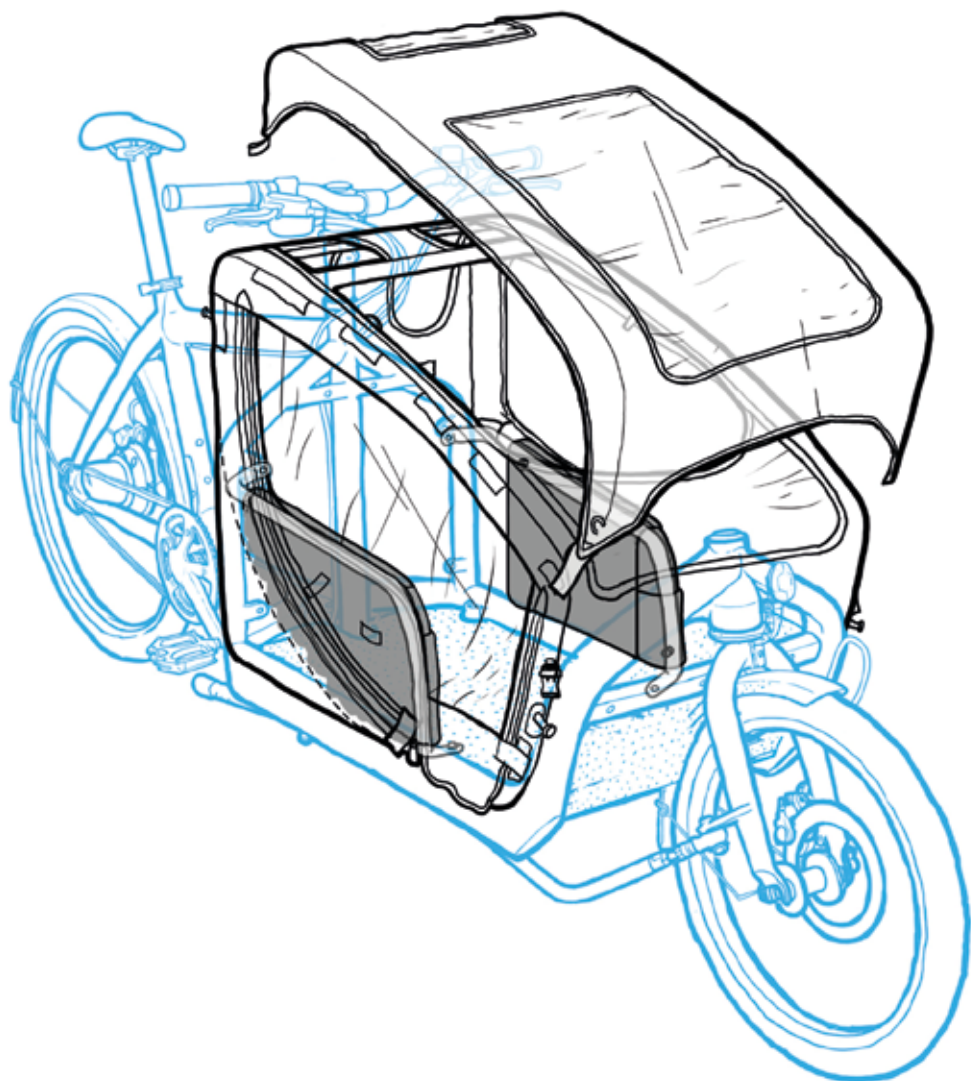

1. Canopy Tent

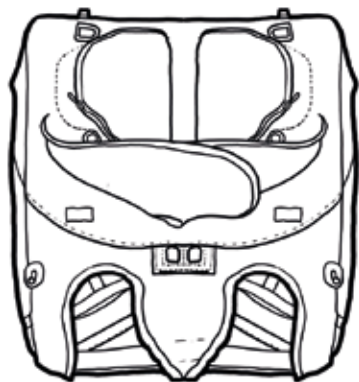

2. Sidebars

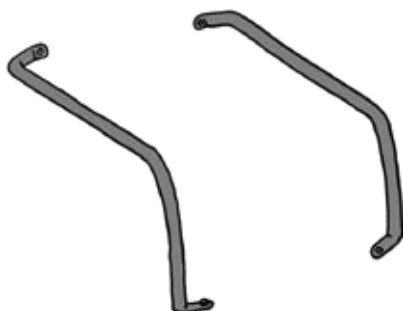

3. Top

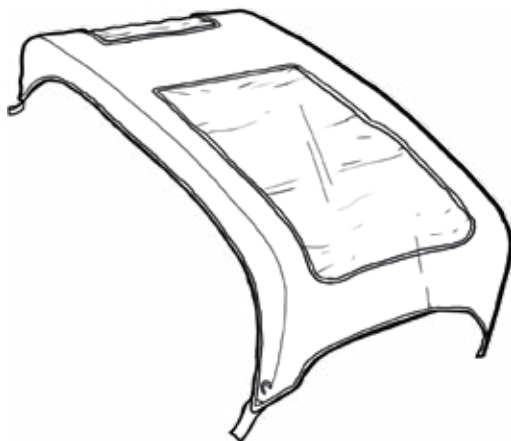

# Step 1

Two tips before you start attaching the Canopy

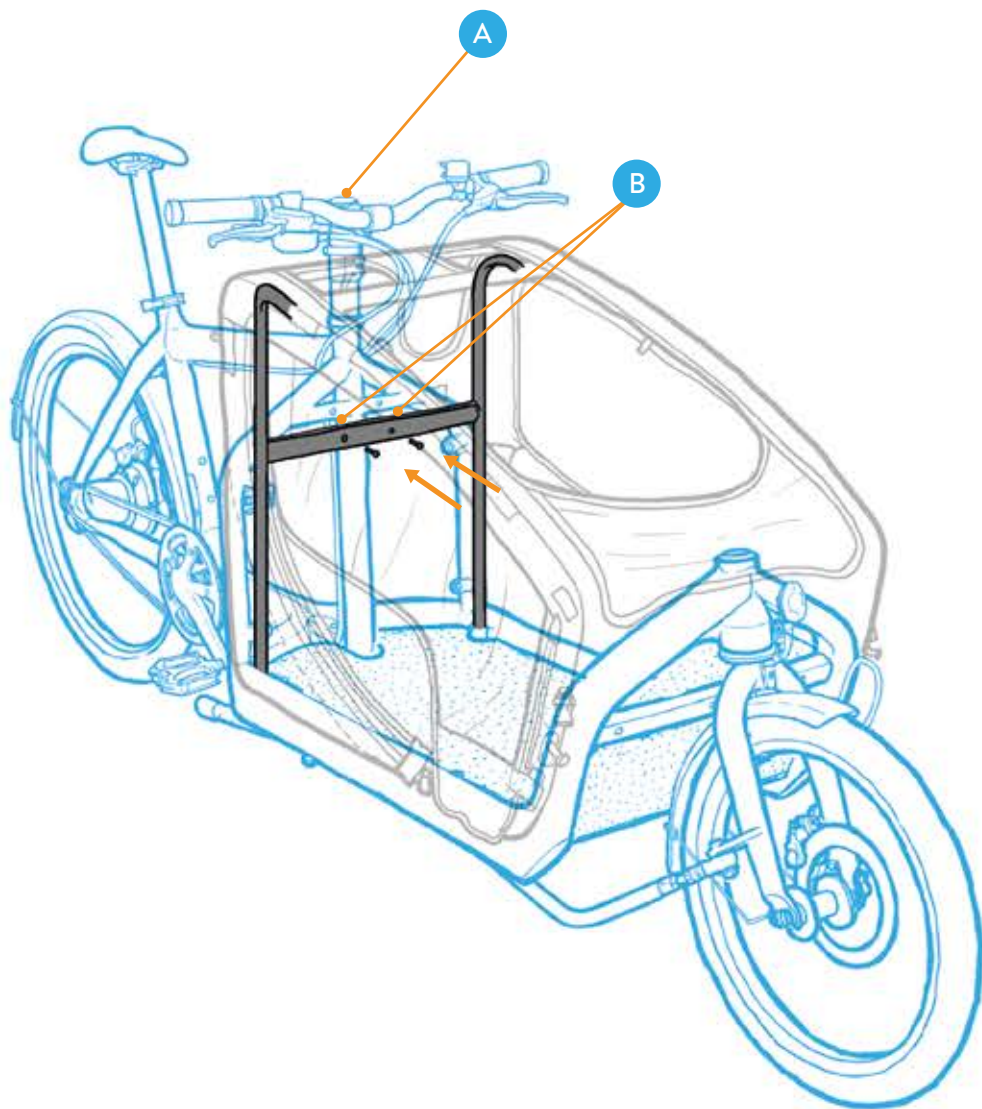

A

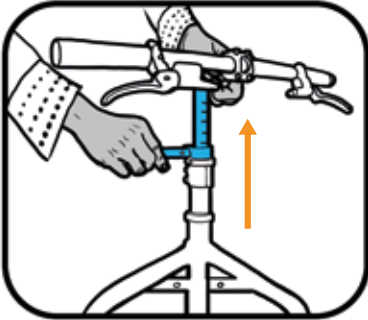

Raise the handlebar to the max. height to make room for the Canopy.

B

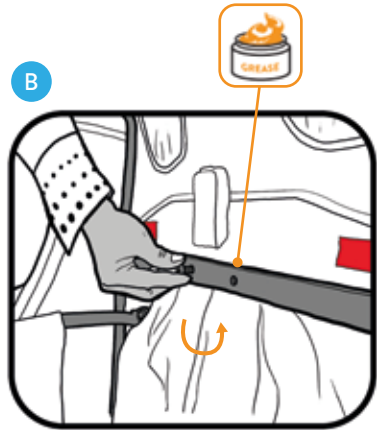

Before attaching the Canopy frame, remove the two bolts inside the Canopy. Use tools 1+2.

Grease the two bolts.

Screw the two bolts through both Canopy frame and Bullitt frame in **Step 2**.

*Larry the King says:*  
“If you have bought the Bullitt Foldable Seat and want to attach it inside the Canopy, you remove the bolts and attach the Seat to the back holes instead”



# Step 2

Fitting the Canopy onto the Bullitt frame

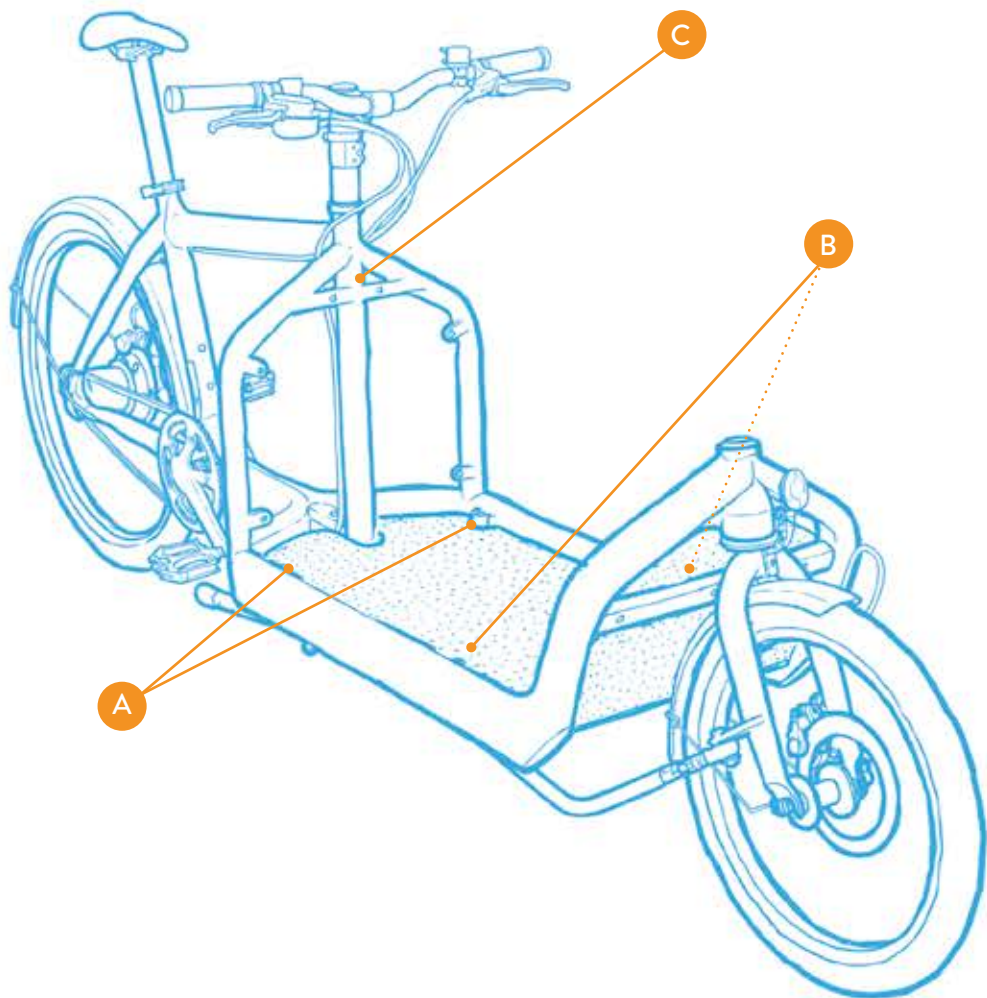



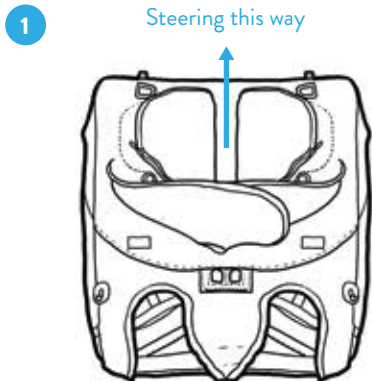

Unfold the Tent, remove all strips and place it on the Bullitt. Backside of the tent facing the handlebar.

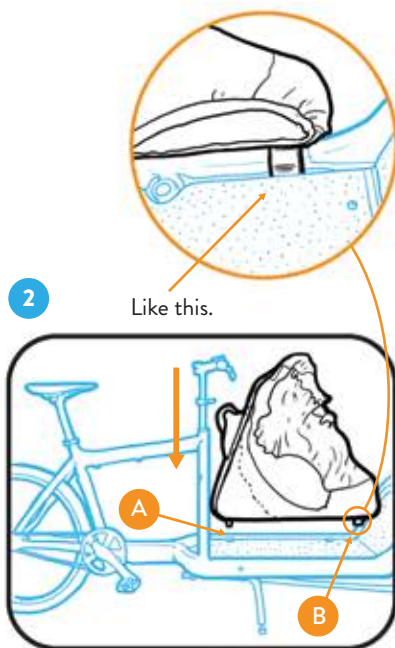

Fit the hook (A) onto the frame and the pin (B) into the back hole on the bottom of the frame.

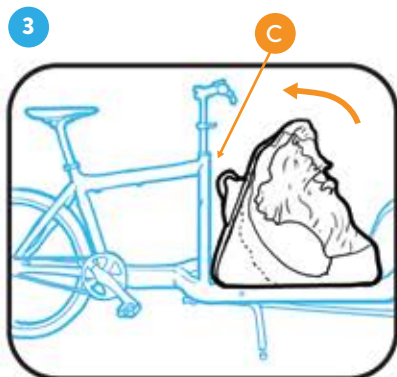

Drag the tent backwards towards the handlebar.

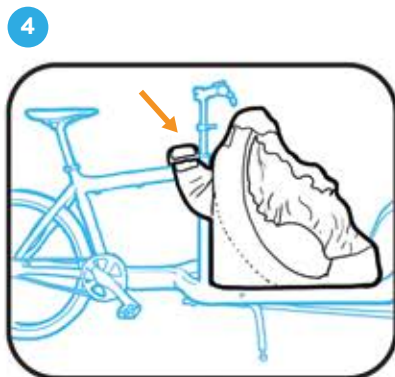

Attach the velcro on the bicycle frame. Remember to screw the two bolts from **Step 1** through both Canopy frame and Bullitt frame.

# Step 3

Assembling the Roof bars

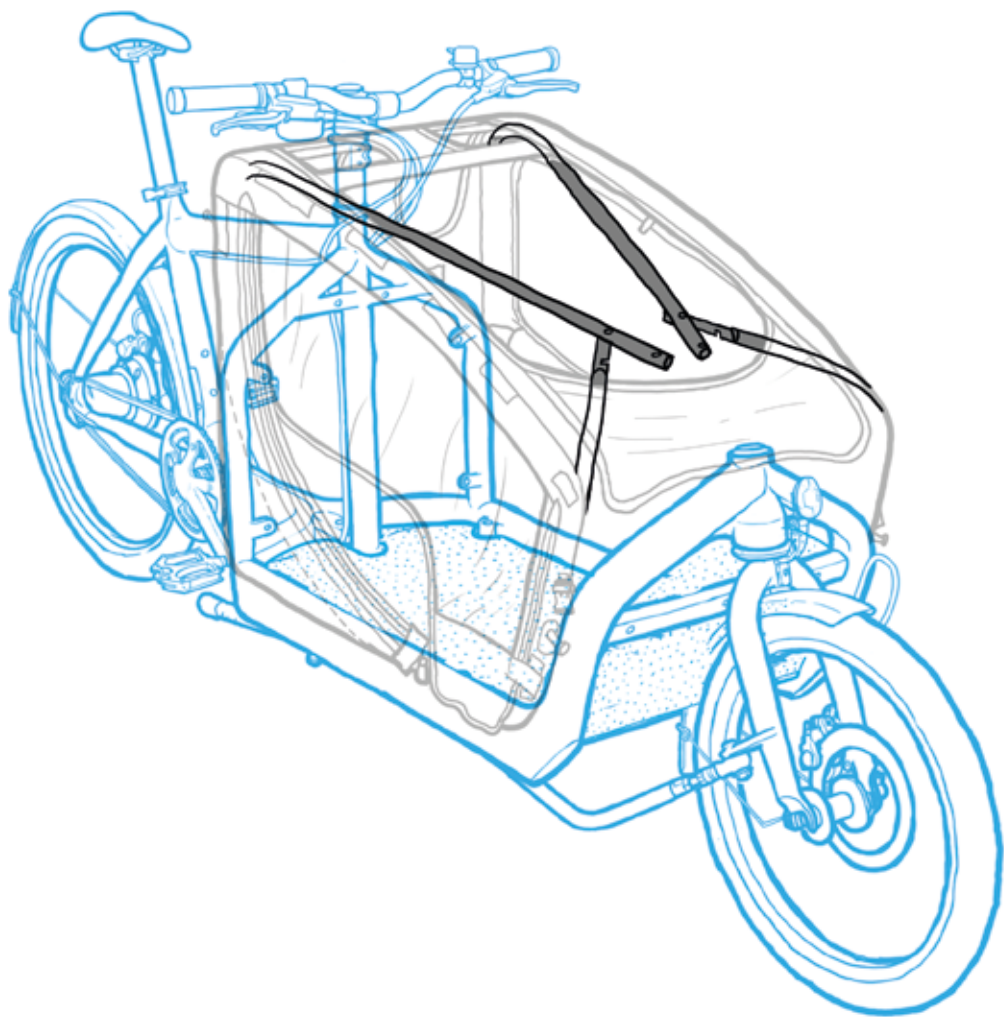

1

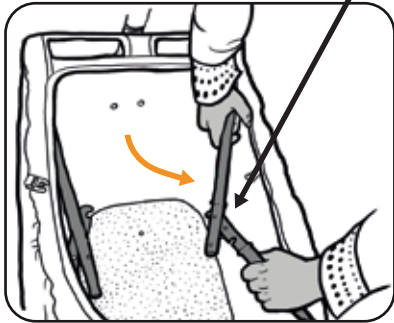

Bend the bars on the roof of the Canopy into position.  
Be careful -you could cut your fingers!

2

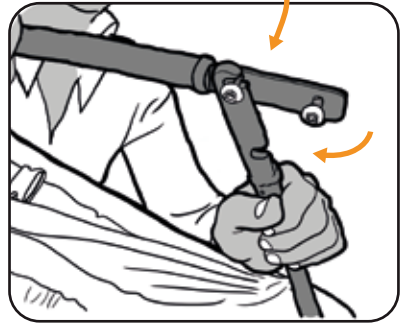

Bottom view.

3

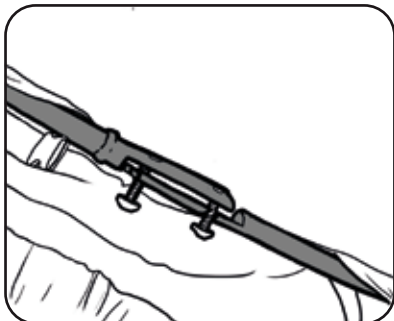

Tighten the screws with Tool 3 (the Hex/Allen Key), and repeat on the opposite side of the Canopy.

# Step 4

## Assembling the Sidebars

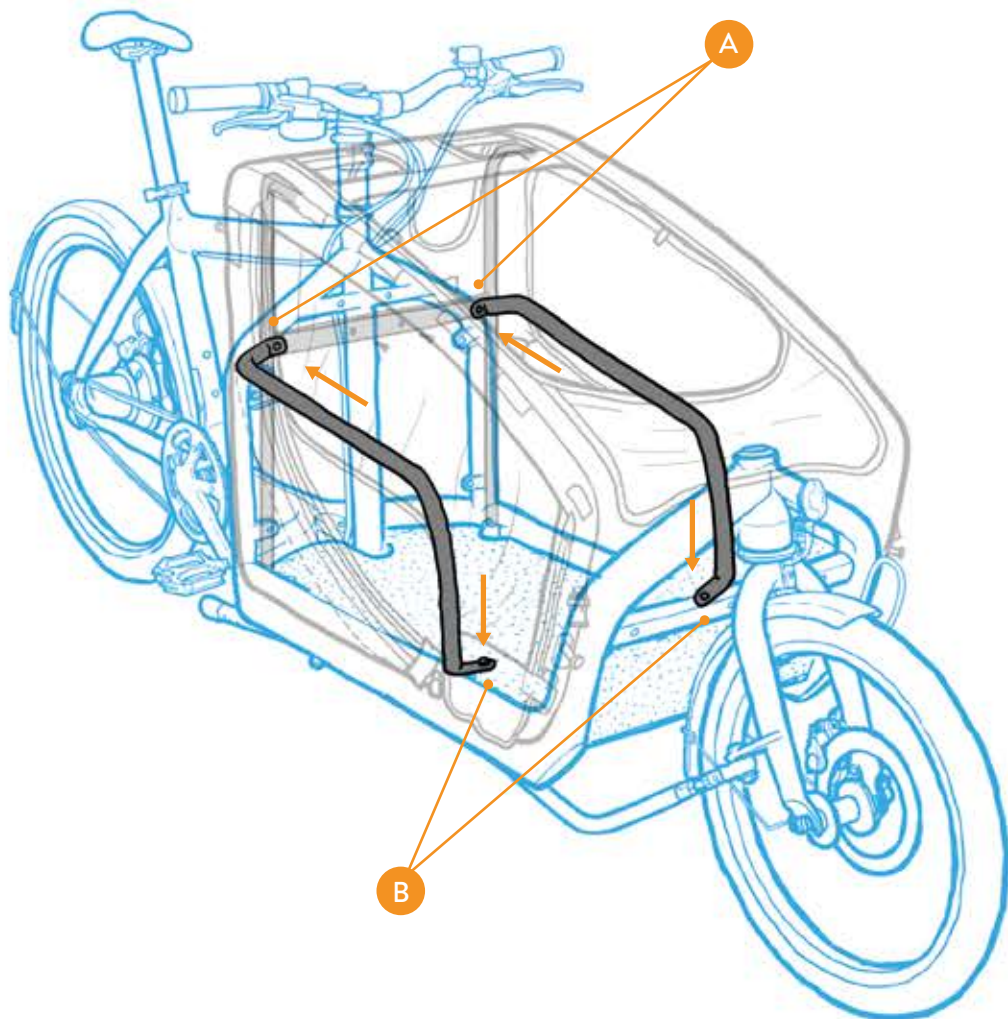

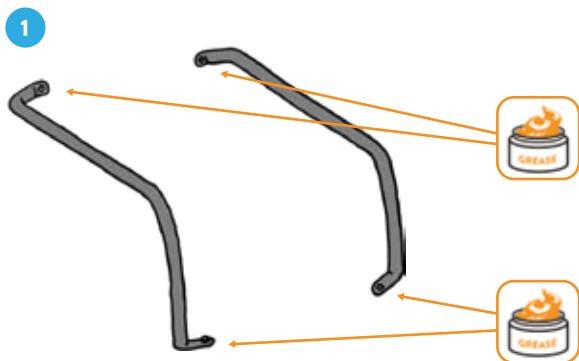

Get your Sidebars. Unscrew the bolts. Notice that the bolts are slightly different. The longer bolts goes on the cargo area on the Bullitt frame.

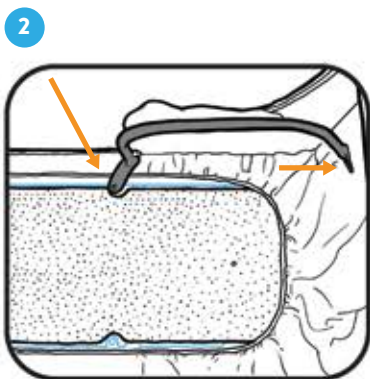

Like this...

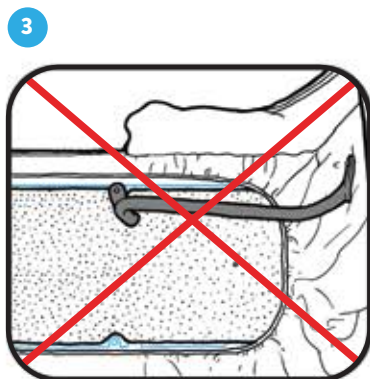

...not like this.

King Larry says:  
"Fit the Sidebars right  
or your ass will  
have to be tight!  
Urghhurh!"



# Step 5

Attaching the Canopy Tent to the Sidebars

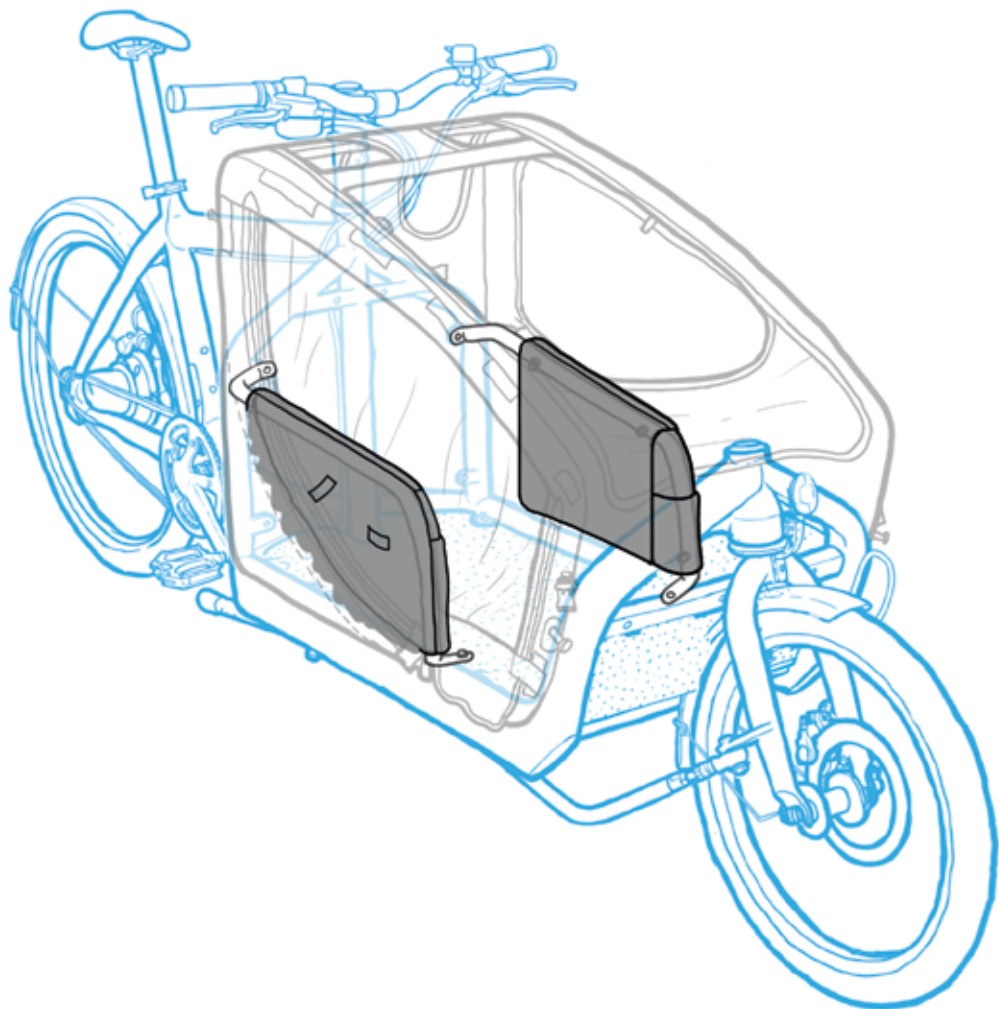

1

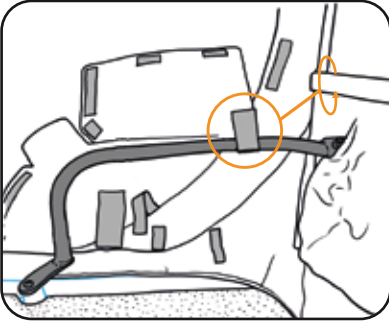

Attach the velcro around the bar.

2

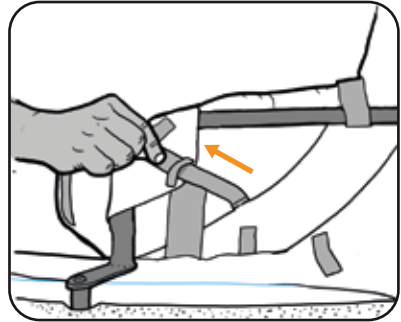

Put the velcro strap through the hole.

3

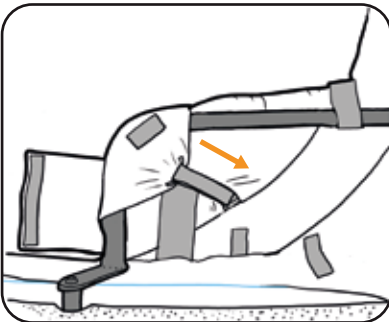

And attach it like dissss!

4

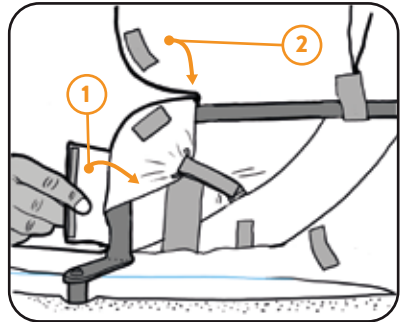

Attach the flaps in the following order.

5

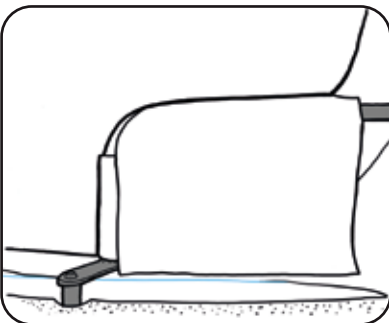

Voila! Finished!

## Step 6

Attach the Top to the Roof bars

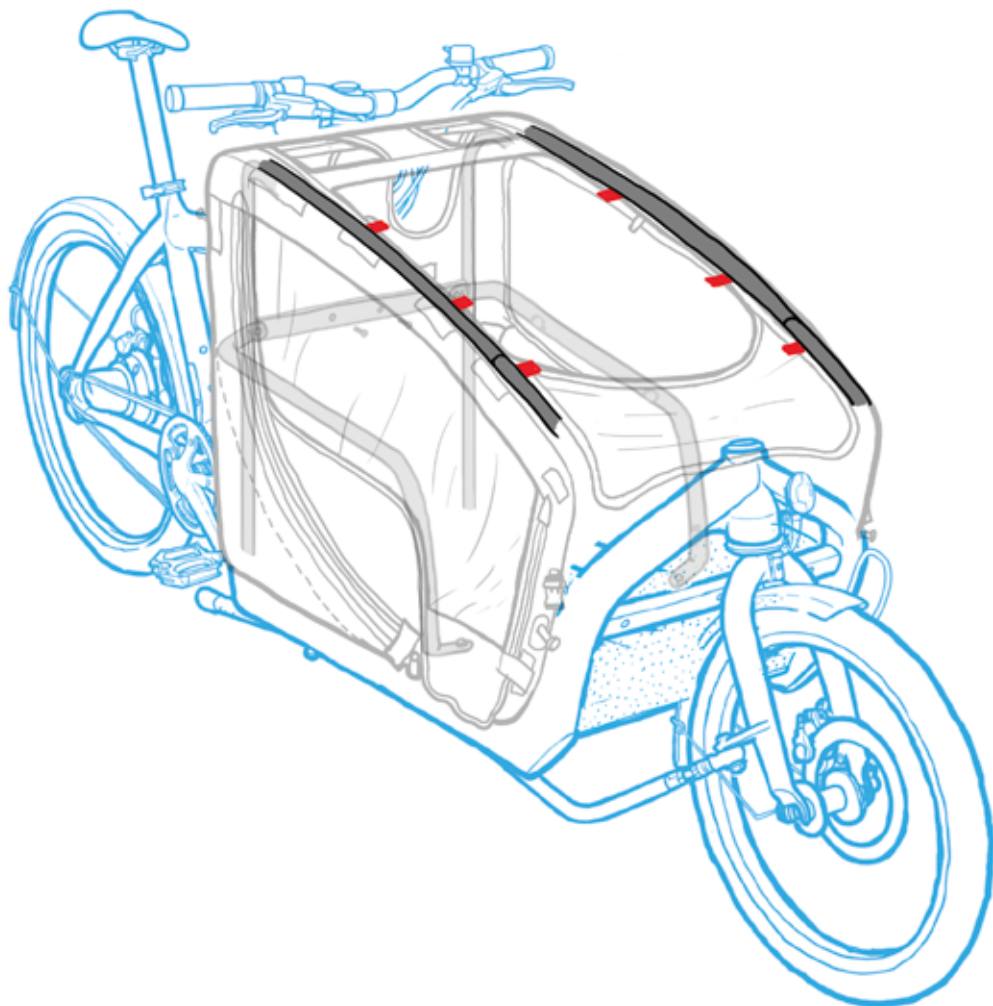



1

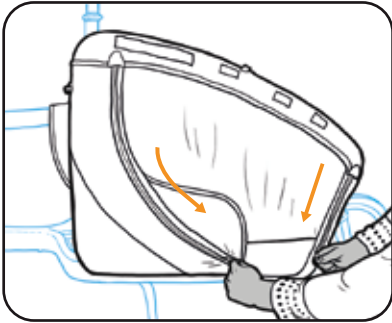

Zip the sides of the windows and attach the velcro so its nice and tight. Do it on both sides of the Canopy.



**Important notice**  
from Larry the King!

When you get to this stage, the best thing is to leave the Canopy rest for **24 hours**. It's so the fabric can stretch. If not patient...



**...This could happen!**

Broken side window or zipper could be the consequence...

We make the only side entrance Canopy in the universe and it has a prize. The prize is patience.

2

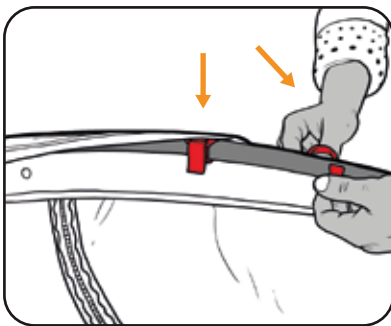

Put the velcro straps through the hole and attach it. Repeat on the opposite side.

3

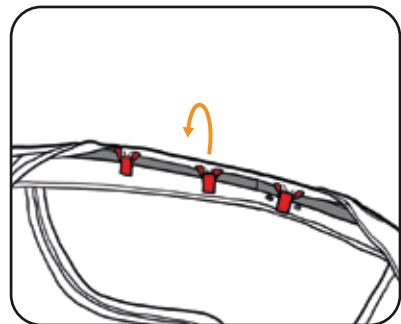

Bend the cover back and you are good to go.

# Step 7

Attaching the Top

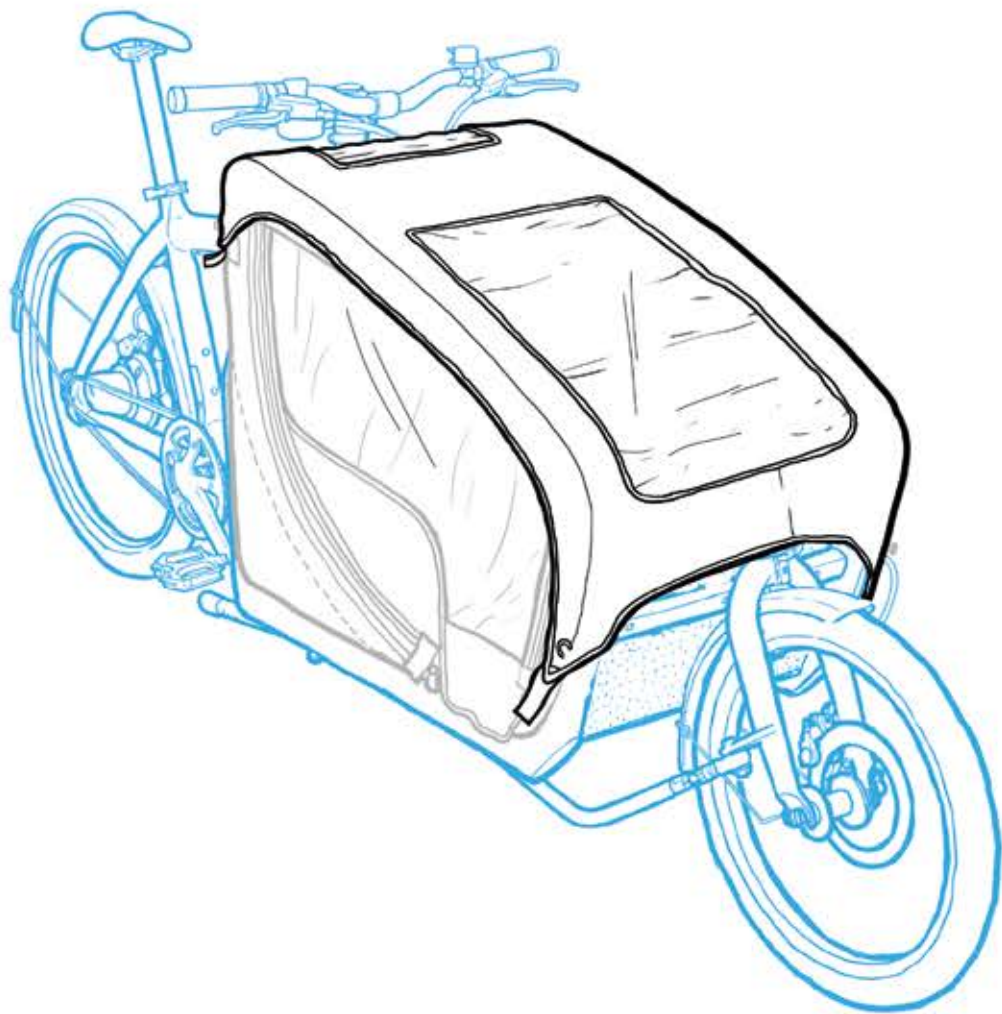

1

A

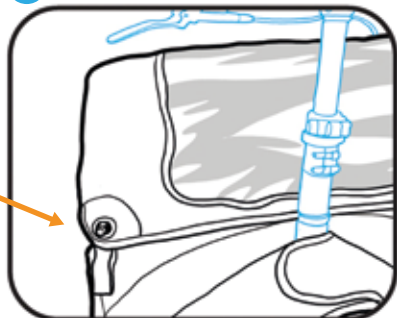

Get your Top and fit the holes (A) on to the back of the canopy on both sides.

2

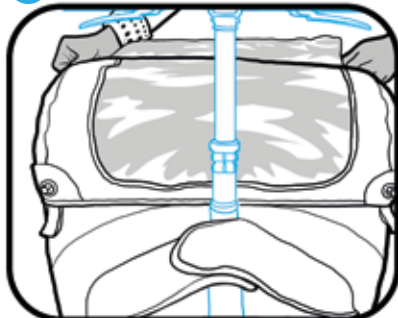

Roll it forward.

3

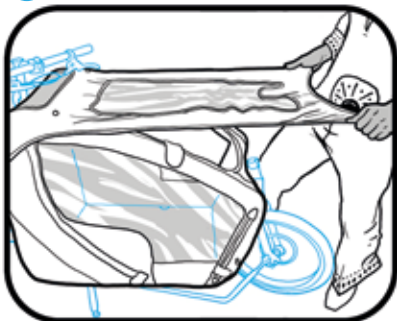

Stretch it forward and attach the holes on each side to the taps on the front of the Canopy.

4

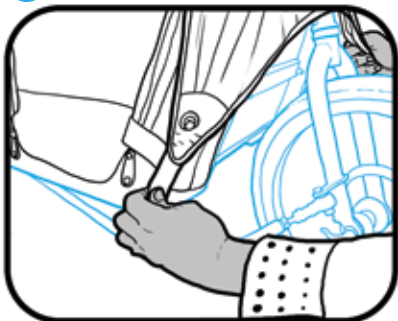

Attach the velcro at the end of each side to the Canopy.

5



Finito!



Bullitt Shop Copenhagen  
Frederiksborggade 43, DK-1371 Copenhagen, Denmark

[www.larrysharry.com](http://www.larrysharry.com)